

THE HEWLETT-PACKARD 3820A ELECTRONIC TOTAL STATION

By TUDOR JONES

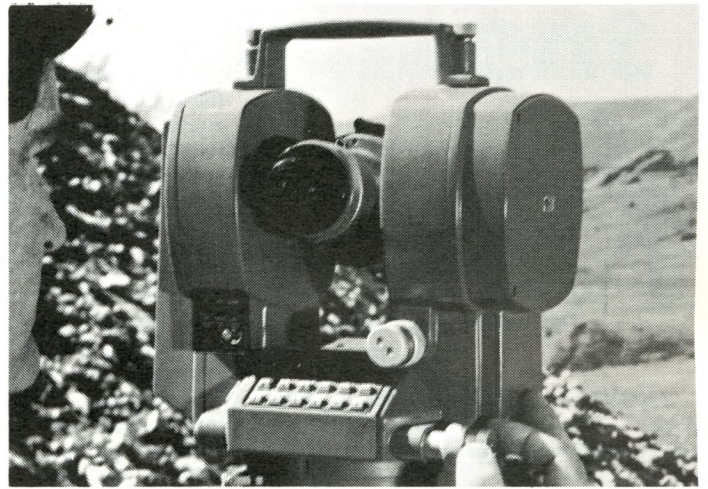

The above is a remarkable new instrument researched, designed and developed by the Hewlett-Packard Company of Palo Alto, California. Its capabilities, as one would expect from Hewlett-Packard, are extensive.

It measures horizontal, vertical and slope distances to 5km, correcting for curvature of the earth, refraction and environmental conditions; measures horizontal and vertical angles to one second, while automatically compensating for instrument mislevel; sends data to an external memory for later processing, or directly to a calculator or computer; tracks any of its measured or computed quantities; and displays the clockwise angle between two consecutive pointings of the telescope.

For user convenience, the 3820 has a full keyboard and display on each side of the instrument.

A 12 oz. Ni/Cad battery housed in the left standard of the instrument provides for up to four hours of continuous operation.

DISTANCE MEASUREMENT

The main components of the electromagnetic distance measuring device are similar to those of other instruments.

The physical size of it has been greatly reduced. For example, the solid state GaAs lasing diode and its controlling circuitry are contained on an integrated circuit only 6 mm in diameter. Power consumption is 1.5 W. The length of the carrier wave is 830 nm, putting it in the infra-red band; the modulation frequencies are 15 MHz, 375 kHz and 3.75 kHz, giving unambiguous distance displays over its 5 km range.

The layout of the optical system is shown in Figure 1.

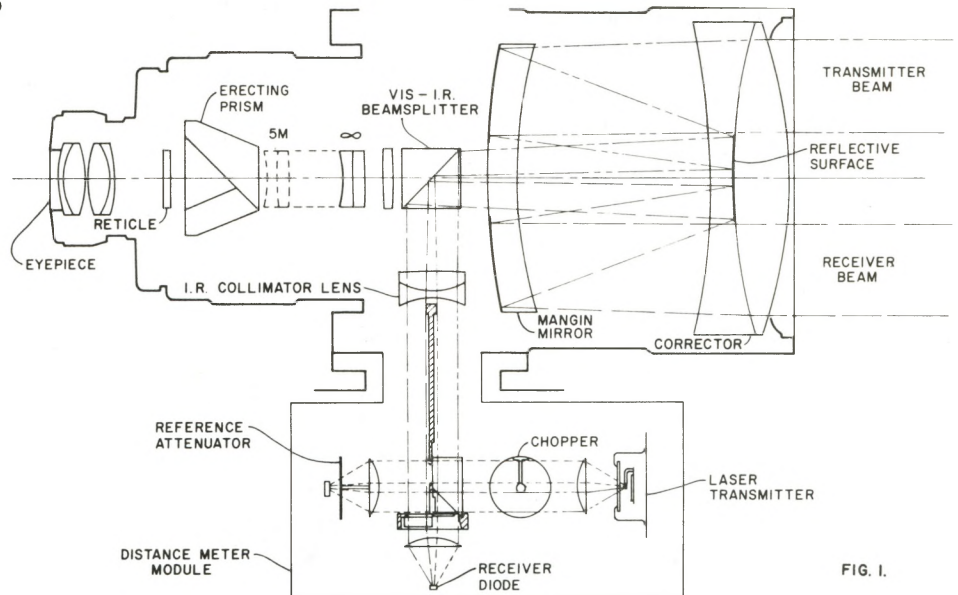

FIG. 1.

A catadioptric telescope is used. This is a reflecting telescope, a bit like the big one on Mt. Palomar. The telescope mirror is spherical to within two millionths of an inch. The horizontal axle of the telescope is machined to a tolerance of 0.001 mm, and when installed in the alidade of the instrument it is monitored by a special electronic gauge to make sure the height of the standards match within 0.002 mm.

For viewing, it is a 30 power telescope. It has an illuminated reticle for night work.

For the E.D.M. side, the optics system is an eight power Galilean telescope. A beam-splitter is used to direct the infra-red light into the distance meter module. It is reflective to the wavelength of the infra-red, but transmits the visible spectrum.

While distance data is being accumulated, the instrument computer keeps a running total of the mean and variance of the readings. If the variance

is within an internal limit, the mean is displayed as the result. If the variance exceeds this limit, the mean is displayed flashing to indicate a marginal result. If no reading can be made, a flashing zero is displayed.

ANGLE MEASUREMENT

The optical sensing of a glass disc has yielded excellent accuracy and stability in traditional modern theodolites, so therefore Hewlett-Packard chose a similar system for the HP3820A. Angles are electronically read from a glass disc with a metal film pattern deposited on it.

As the zenith angle must be an absolute value referenced to gravity, an absolute reading system was chosen instead of an incremental one. The identical electrical and optical system is used for both the horizontal and vertical circle. Interpolation is achieved by phase measurement. The phase meter is shared by the two circles, the level sensor and the E.D.M.

The encoder disc has three distinct

patterns upon it, and sensing is accomplished by three separate measurements.

Firstly, the instrument measures an eight bit Gray code which locates position to 1 part in 256. This uses an optical readout system, very similar to the glass wedge set-up in the Reg Elta 14.

The codes most commonly employed in these optical systems are usually a variant of a binary or a decimal code or a combination of the two. It is obvious that to increase the resolution of the coded disc pattern it is only necessary to increase the number of tracks. But there are serious practical limitations to this simple idea which must be carefully considered if gross reading errors are to be avoided. One of the consequences of using too many tracks is that the alignment of the photo-detectors becomes ultra-critical.

For example, if the end L.E.D. of a row of L.E.D.'s were slightly out of alignment and the optical system read '01111111' instead of '11111111', then a reading of 127 would occur instead of the correct one of 255, a catastrophic mistake of over one hundred percent.

A protection against this is to adapt the code by making it progressive, so that every transition from one sector to another corresponds to a change of the pattern in only one track. Such a code was devised by H. T. Gray in 1953 in London, England, and is now known by this inventor's name.

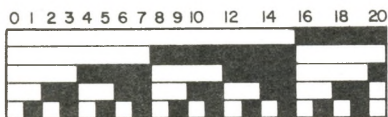

PURE BINARY CODE



GRAY CODE

FIG. 2

In Figure 2 you will see how the pure binary and the Gray codes compare. Examining each track independently, you will note that in the Gray code, alternate 'blocks' have been flipped over or moved up to touch the adjacent block. In track 1 (the bottom one), every alternate block moves up one space, in track 2 they move up two spaces, in track 3 four spaces, and so on.

Note that as the Gray code passes between a set of diodes and detectors,

only one detector will change its state, or signal, at each transition point.

Thus no greater error than one unit of a decimal number can occur during passage from one sector of the disc to another.

The conversion from Gray code to binary is carried out electronically, and can be done in several ways. A typical method is described.

Starting with the M.S.B. (most significant bit) of the Gray code word, the computer counts the number of ones one bit at a time, two bits at a time, three bits at a time, and so on, until the whole word has been dealt with, and then it writes the corresponding straight binary bit according to the rule:-

if the number of ones is odd, write down a 1, if the number of ones is even, write down a 0.

When the Gray code word is presented M.S.B. first to the input of an appropriate circuit chip, its output will be translated to straight binary according to the above rule.

Table 1 shows how decimal eighteen converts from Gray code to binary.

| | GRAY CODE | | | | BINARY | | | |
|--|-----------|---|---|---|--------|---|---|---|
| | MSB | | | | MSB | | | |
| EIGHTEEN | 1 | 1 | 0 | 1 | | | | |
| No. OF ONES IN FIRST DIGIT IS ODD. | 1 | | | | 1 | | | |
| No. OF ONES IN FIRST TWO DIGITS IS EVEN | 1 | 1 | | | 1 | 0 | | |
| No. OF ONES IN FIRST THREE DIGITS IS EVEN. | 1 | 1 | 0 | | 1 | 0 | 0 | |
| No. OF ONES IN FIRST FOUR DIGITS IS ODD. | 1 | 1 | 0 | 1 | 1 | 0 | 0 | 1 |
| No. OF ONES IN FIRST FIVE DIGITS IS EVEN. | 1 | 1 | 0 | 1 | 1 | 0 | 0 | 1 |

TABLE 1.

In the photograph of the encoder disc in Figure 3, the building-block effect of the Gray code can be clearly seen.

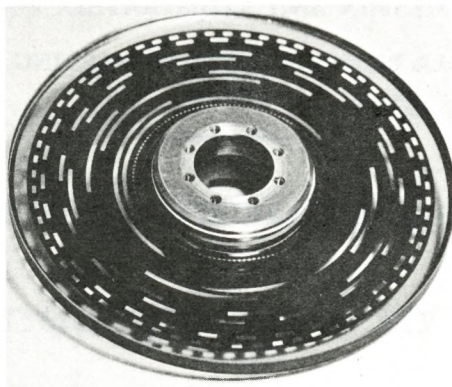

FIG. 3 - Glass Encoder Disc

A cross section of the optical sensing system is shown in Figure 4.

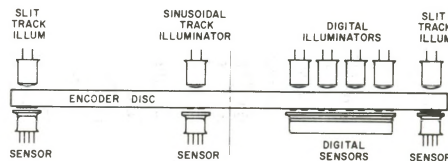

FIG. 4 - Optical Sensing System

SINUSOIDAL TRACKS

Secondly, the instrument interpolates a 128 period sinusoidal track. The interpolator divides each period into one thousand parts. Thus, the circle is divided in 128 000 increments, each increment being approximately ten seconds of arc.

This is an extremely sophisticated operation.

Some data is available to illustrate the principle of interpolation.

Figure 5 shows the track which varies sinusoidally in width. The wavelength of the pattern is 1.08 mm; the maximum amplitude 0.6 mm. Four photo-diodes are spaced at ninety degree intervals with respect to the sinusoidal

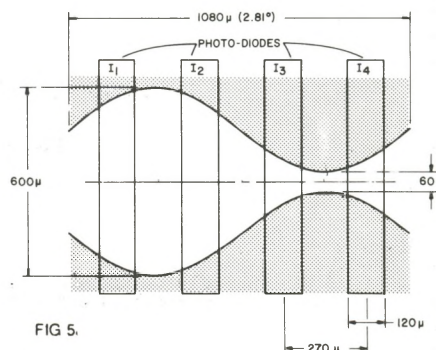

FIG. 5.

period. Each diode senses the fluctuating light emitting from the track illuminator (Fig. 4), which is pulsing at 375 Hz. The alternating photo-currents generated depends on the illuminated areas of the diodes which are, in turn, dependent on their positions with respect to the pattern.

The phase outputs of diodes 1 and 3 are combined. The outputs of diodes 2 and 4 are combined. These two signals are now processed in such a manner that signal 1-3 is phase shifted ninety degrees in time with respect to 2-4. These are now summed in an operational amplifier, and the resulting signal presented to the phasemeter where it is compared with the reference current that is pulsing the track illuminator.

The phasemeter has a resolution of 1000, as you will have inferred from the 15 MHz fine distance measuring frequency.

Finally, the instrument interpolates a 4096 radial slit track. Again, each period is divided into 1000 parts. This divides the circle into 4 096 000 increments resulting in a true 1cc-grad resolution.

The 4096 radial slit track uses the same interpolation technique as the sinusoidal track. On this track, however, the sinusoidal pattern is on the photo-detectors while the bar pattern is on the circle.

If the information on the first track is sparse, on the second it is non-existent. As a member of the Hewlett-Packard Co. said, "If anyone wants to copy us on this instrument, they are going to have to figure out that little bit for themselves!"

The computer in the instrument combines the readings of the three sensor systems to produce an absolute reading.

The HP3820A utilizes a micro-processor derived from HP pocket calculator technology to perform all of the various functions within the instrument.

GRAVITY SENSING SYSTEM

In the instrument, the vertical compensator and trunnion axis plate level are combined in a two axis level sensor. This device eliminates the need for precise leveling; the instrument still has to be levelled to use the optical plumb.

Figure 6 shows the optical layout of the level sensor. A mercury pool damped with silicone oil is used to establish the direction of gravity. The interpolation technique is the same as used for angle measurement. Figure 7 illustrates the sinusoidal transparent slits and the four diode sensors arranged orthogonally for the two axes.

To prevent erroneous readings when the interpolators exceed their range, a limit sensor is incorporated. When in range, the limit sensor remains illuminated. If the range is exceeded, however, the limit sensor is no longer illuminated and a display indicator is flashed to inform the operator. To determine the level within 1 cc-grad, the pattern is read to 0.7 μm . Cross axis movement combined with the 1 mm height of the photo-diodes limit the range to plus or minus 150 seconds.

DIGITAL OUTPUT

The instrument is equipped with a peripheral device for recording or processing. Data is brought out via slip rings to a five pin connector on the fixed instrument base.

The HP3820A outputs a 56 bit word consisting of 14 BCD digits. Each word contains nine digits of data and five digits of status information.

The portable data collector, the HP3851A, has a battery powered semi-conductor memory and can store 1000 lines of data.

Semi-conductor memories allow for very fast read/write speeds. A major disadvantage to the user, however, is that they are volatile in that memory contents are lost if the power goes off. Safeguards built into the 3851A ensure that this event is unlikely to occur.

A built-in battery maintains memory for up to ten hours. An auxiliary battery maintains memory for one hour while the main battery is being changed. Special interlock circuits prevent accidental erasure even if the unit is turned off.

The assistance of Mr. H. Wylupski in Ottawa, and of Messrs. G. McCormack and A. Gort of Loveland, Colorado, all of Hewlett-Packard, is gratefully acknowledged. Figure 2 and Table 1 are by Mr. R. Grant, Surveys and Mapping, City Hall, Ottawa.

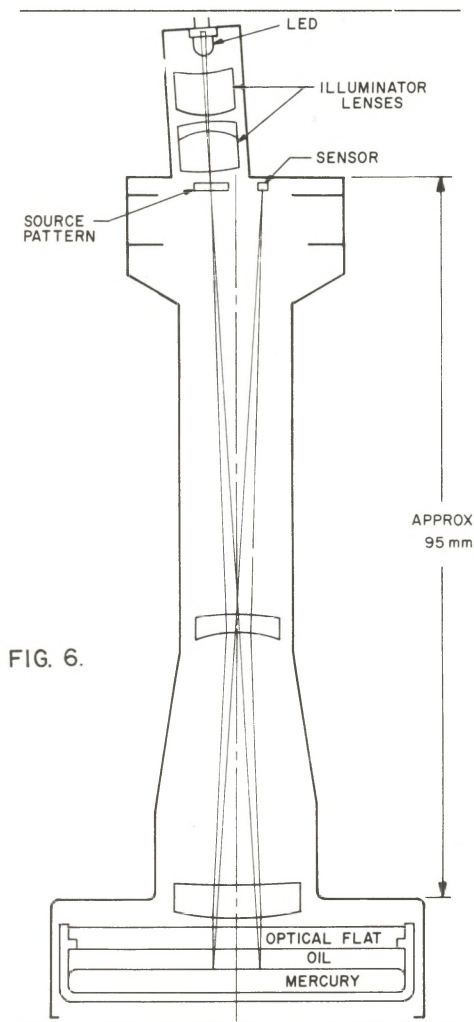

FIG. 6.

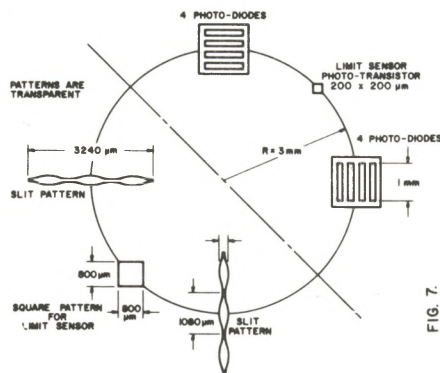

FIG. 7.

